

# KT-LCD3

## User Manual eBike Special Meter



English

# PREFACE

This manual aims to help the user understand and familiarise themselves with the meter function, operation of the meter, how to set the project parameters, how to achieve the best match of the three (motor, controller, and meter) to improve electronic control performance of the electric motor. This manual covers installation, operation, parameter setting of the meter and how to use it properly, which help user resolve issues that arise from use.

## OUTLOOK AND SIZE

### Meter Dimension

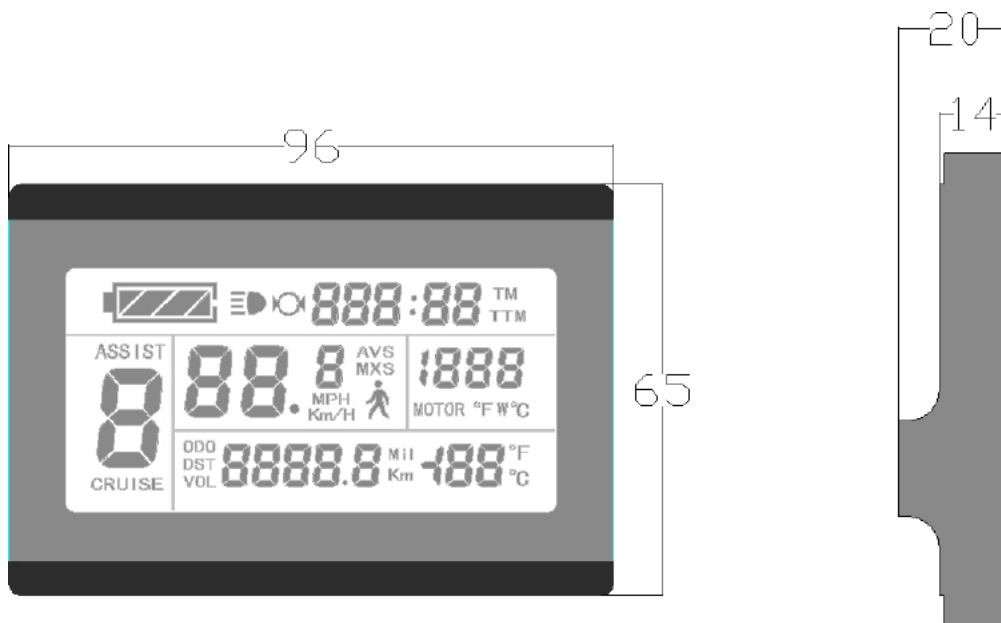

### Meter Dimension

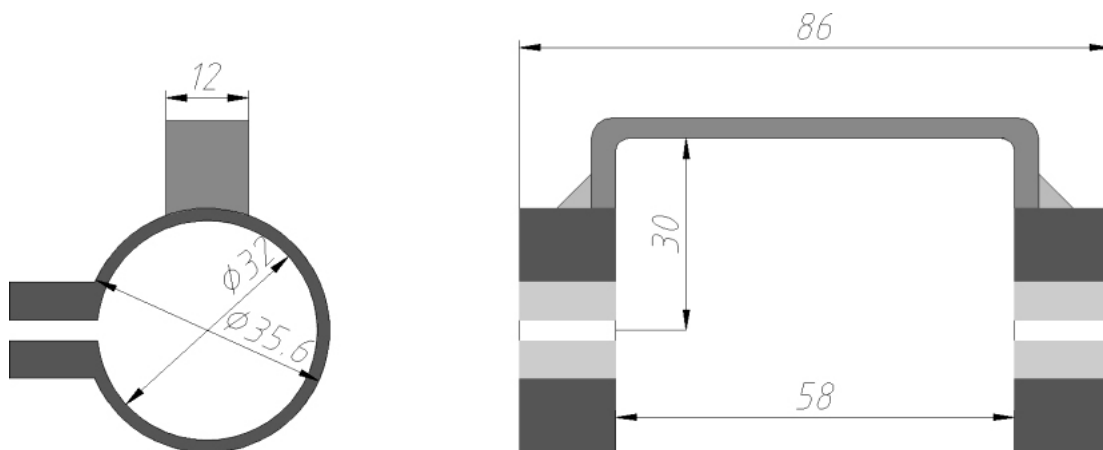

### Dual Bracket Mounting Dimension

## Button Box Dimensions

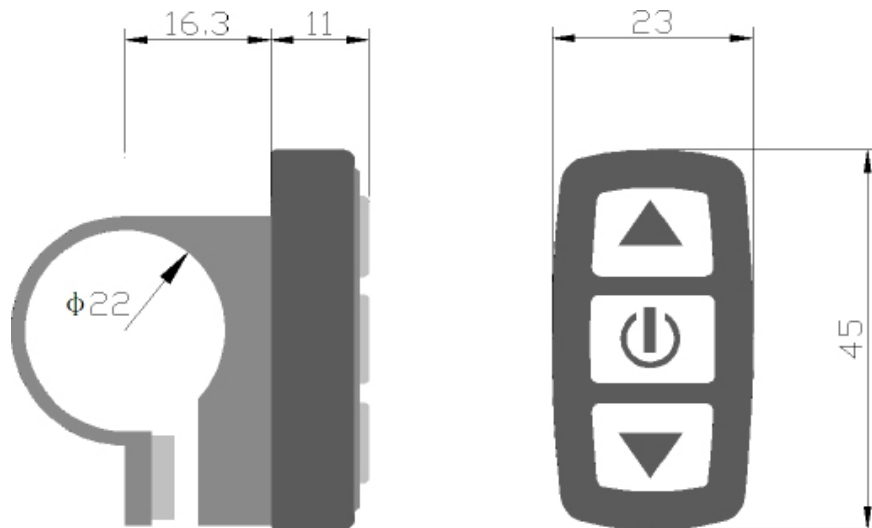

## Main Material and Colour

The KT-LCD3 and button box are primarily constructed of polycarbonates (PC) and are of a dark gray or white colour.

## Wiring Schematic

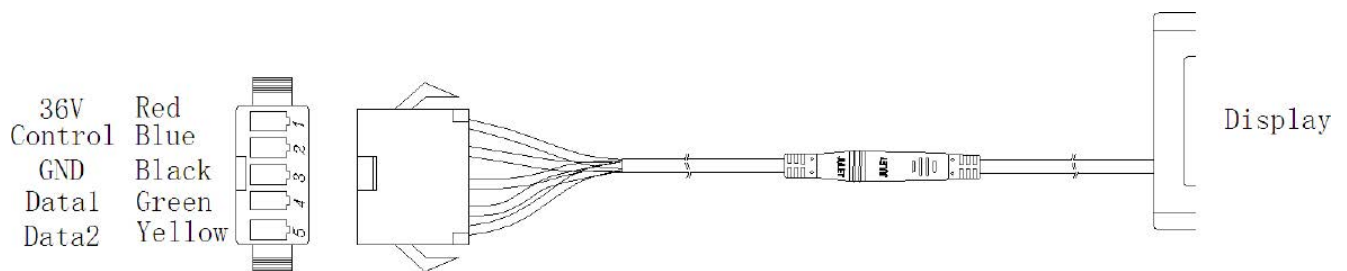

# Contents

<b>Preface</b>	2
<b>Outlook and Size</b>	2
<b>Installation Instruction</b>	6
<b>Function Overview</b>	7
<b>Display Content</b>	7
<b>Button Definition</b>	8
<b>Basic Operation</b>	8
On/Off	8
Display Interface	8
Battery Capacity Indicator	12
PAS Ratio	12
Power Push Function	13
Cruise Function	13
Backlight and Headlights	13
Motor Operating Power and Temperature	14
Ambient Temperature	14
Single Data Clearing	14
Automatically Prompt Interface	15
<b>User Setting Project</b>	16
<b>General Project Setting</b>	16
Maximum Trip Speed	16
Wheel Diameter	17
Units	17
<b>P Parameter Setting</b>	18
P1 Motor Characteristic Parameter Setting	18
P2 Wheel Speed Pulse Signal Setting	18
P3 Power Assist Control Setting	19
P4 Throttle Start-Up Setting	19

P5 Power Monitoring Setting.....	20
<b>C Parameter Setting</b> .....	<b>20</b>
C1 Throttle Start-Up Setting.....	21
C2 Motor Phase Classification Coding Mode.....	22
C3 Power Assist Ratio Gear Initialization.....	22
C4 Handlebar Function Setting.....	23
C5 Handlebar Function Setting.....	23
C6 Handlebar Function Setting.....	24
C7 Cruise Function Setting.....	25
C8 Motor Operating Temperature Display Setting.....	25
C9 Startup Password Setting.....	26
C10 Restore Default Setting.....	27
C11 Meter Attribute Setting.....	27
C12 Controller Minimal Voltage Setting.....	28
C13 ABS Brakes and Anti-Charge Control Setting.....	29
C14 Power Assist Tuning Setting.....	30
<b>Parameter Copy</b> .....	<b>30</b>
<b>Version Information</b> .....	<b>31</b>
<b>Contact Us</b> .....	<b>32</b>

# INSTALLATION INSTRUCTION

Using the appropriate methods and fixtures, mount the LCD screen and button box onto the handle bar to the rider's desires. Refer to the following images below for installation on specific handle bar diameters. While the vehicle is off, connect the necessary wiring and check to make sure all connections are firmly attached. Finally, remove the protection film from the display.

## Ø 31.8 Handlebar Diameter Install

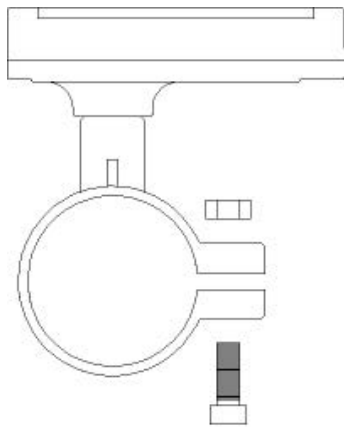

Lateral View

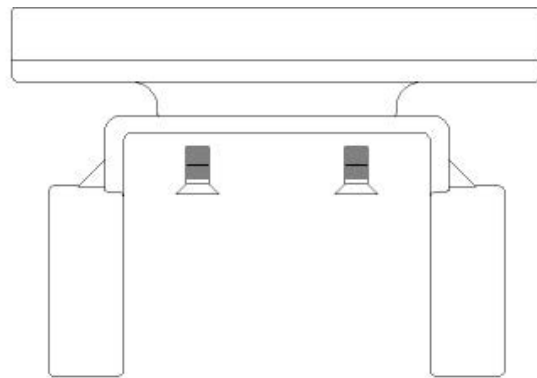

Meter and Dual Bracket View

## Ø 22.2 Handlebar Diameter Install

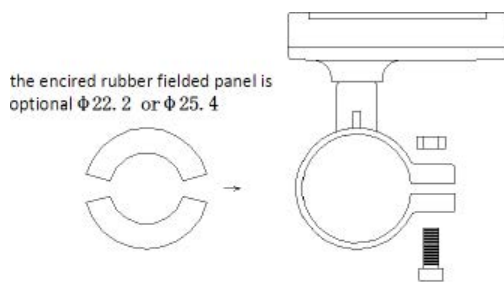

Lateral View

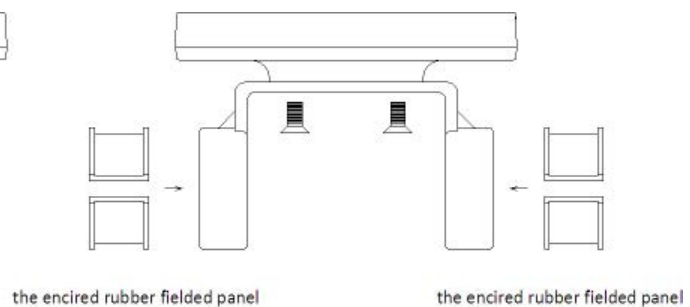





Meter and Dual Bracket View

## Installed KT-LCD3



# FUNCTION OVERVIEW

KT-LCD3 meter provides a variety of functions such as vehicle controls and vehicle status digitized displays to meet the trip demands.

- ◇ Trip time display (with displays of a single trip time (**TM**) and total trip time (**TTM**));
- ◇ Trip speed display (with displays of real-time speed (Km/H or MPH) and a single maximum speed (**MXS**) and a single average speed (**AVS**));
- ◇ Trip distance display (with displays of a single trip distance (**DST**) and total trip distance (**ODO**));
- ◇ Display of turned on handlebar;
- ◇ Display of power-assist startup;
- ◇ Power assistant ratio (or handlebar) gear (**ASSIST**) switch;
- ◇ 6Km/H power push (  ) function;
- ◇ Cruise function (**CRUISE**);
- ◇ Battery capacity indicator (  );
- ◇ Real-time battery voltage (**VOL**) display;
- ◇ Motor power and temperature (**MOTOR**) display;
- ◇ Brake display (  );
- ◇ Turn on backlighting and lights (  );
- ◇ Environment temperature (**°C or °F**) display;
- ◇ Data clearing;
- ◇ Fault code display;
- ◇ User parameter setting
- ◇ 24V, 36V, 48V supply voltage can automatic identification and be compatible

# DISPLAY CONTENT

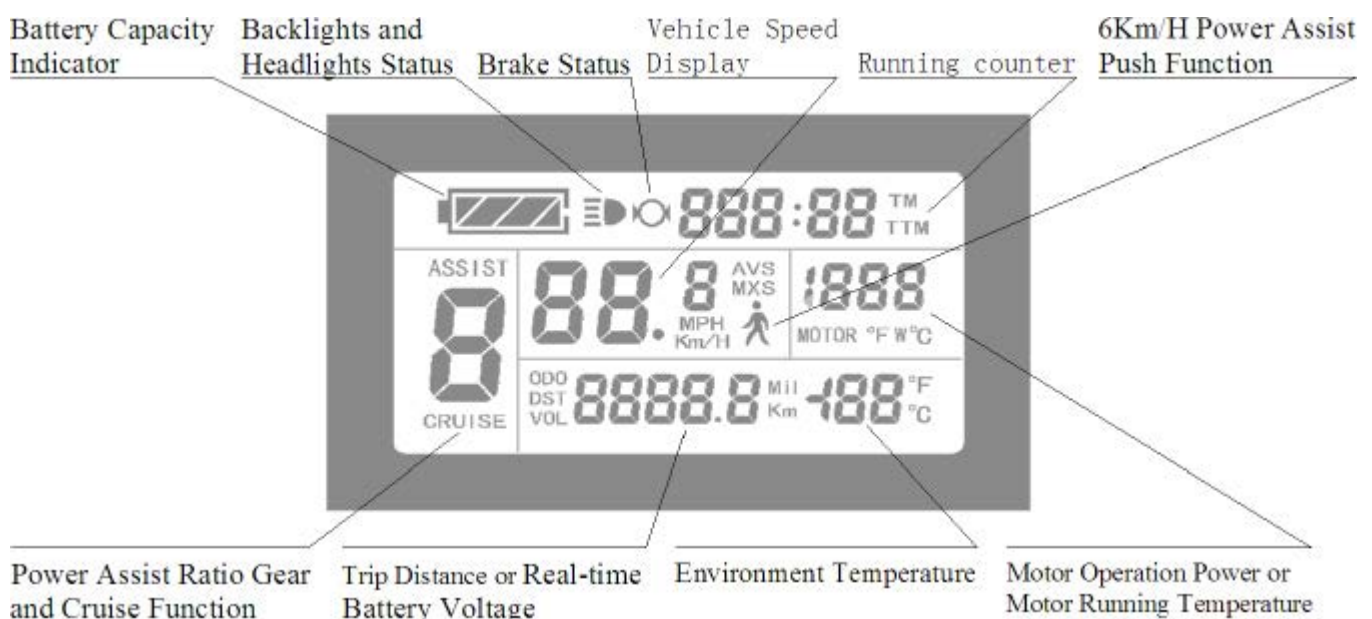

# BUTTON DEFINITION

KT-LCD3 meter adopts the structural form with part design between the main part and operating buttons.

There are three buttons on the operating panel of the box, which are icons of  button (UP),  button (DOWN) and  button (POWER).



**Button Box and Operating Panel**

# BASIC OPERATION

## On/Off

To turn on or off, hold down  button for 2 seconds. System will automatically shut down when vehicle is stationary and not in use for longer than five minutes. When powered off, the power consumption of the meter and controller is zero.

## Display Interface

**Display 1:** The meter is configured to enter this display on start-up.



The following are shown on display 1.

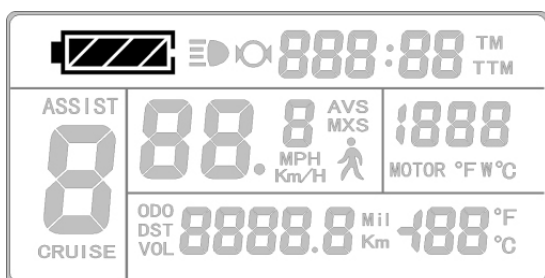

**Battery Capacity Indicator**

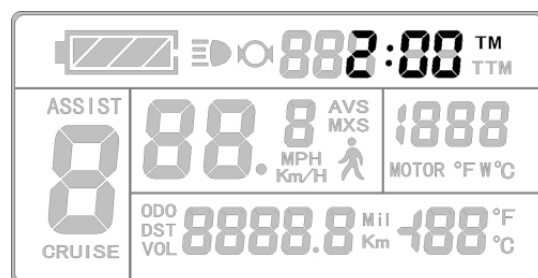

**Single Trip Time (TM)**



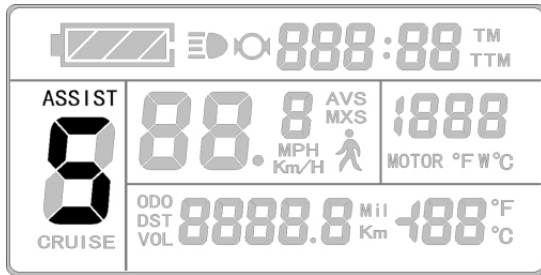

**Power Assist**

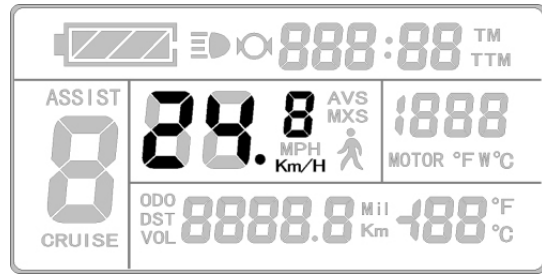

**Real-Time Trip Speed (Km/H)**

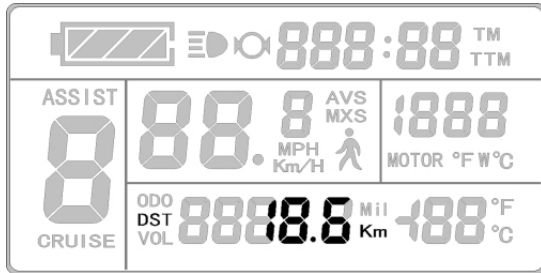

**Single Trip Distance (DST)**

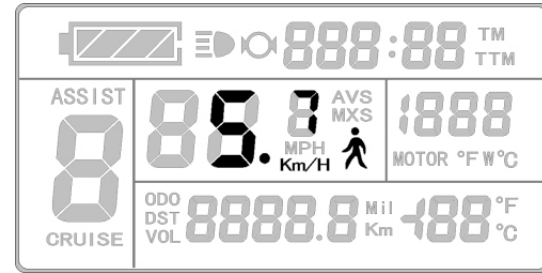

**6Km/H Push Function**

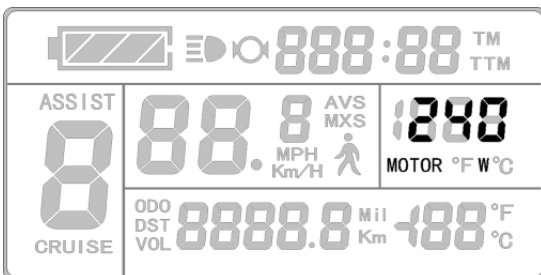

**Motor Operation Power**

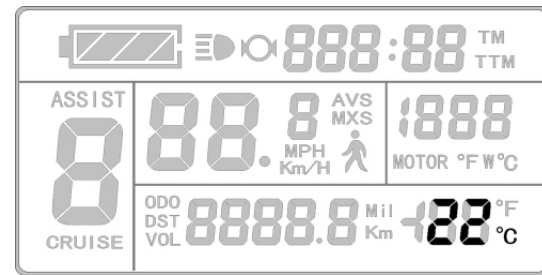

**Environment Temperature**

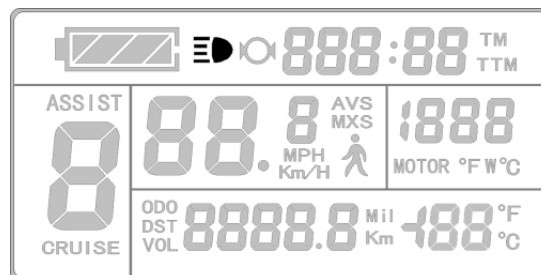

**Backlight and Headlights**

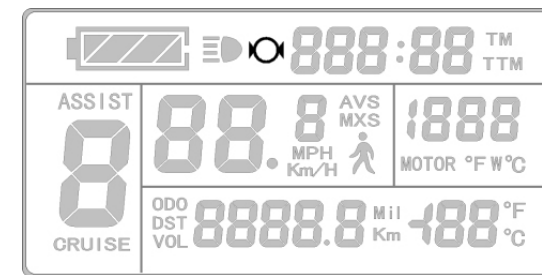

**Brake Status**

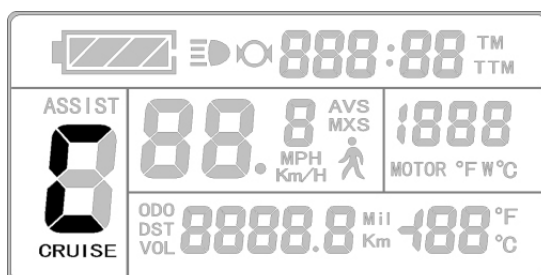

**Cruise Function (CRUISE)**

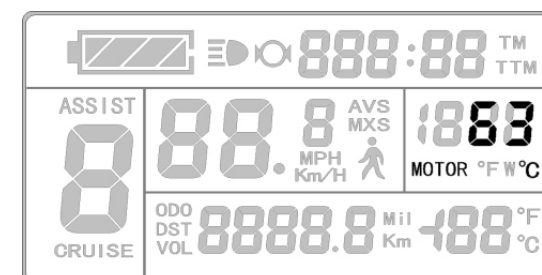

**Motor Running Temperature**

**Display 2:** To enter display 2, press the  button whilst in display 1. The interface will display as shown below.



**Display 2**

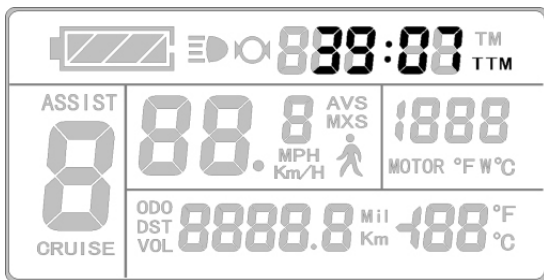

**Total Trip Time (TTM)**



**Total Trip Distance (ODO)**



**Single Average Speed (AVS)**

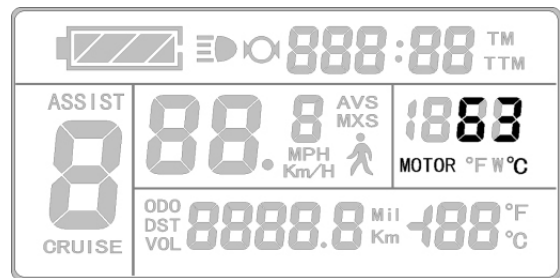

**Motor Operating Temperature**

Once the vehicle is in riding mode, after five seconds display 2 automatically reverts to display 1. The original motor power is replaced by the motor running temperature as shown below. To return to motor output, cycle through the displays back to display 1.



**Display 3:** To enter display 3, press the  button whilst in display 2. The interface will display as shown below.

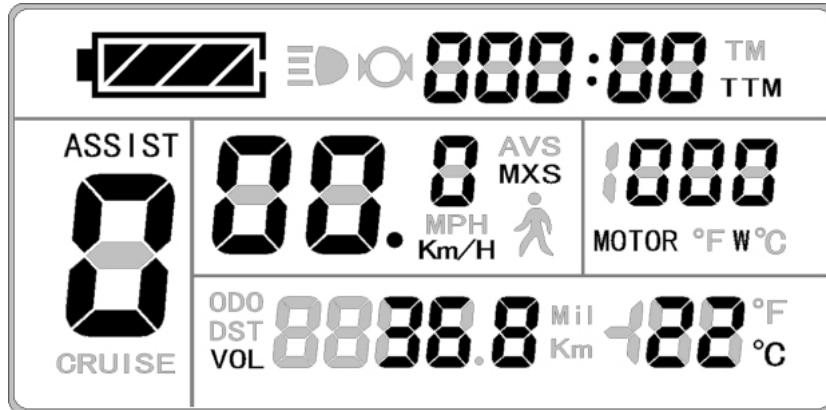

**Display 3**

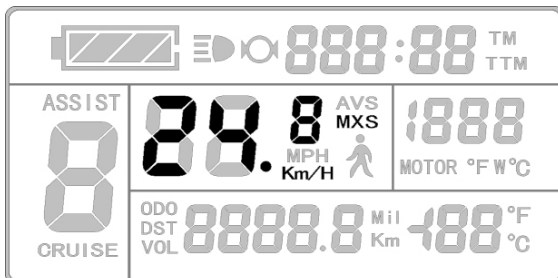

**Single Maximum Speed (MXS)**

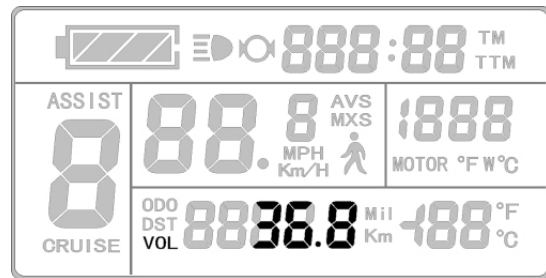

**Real-Time Voltage (VOL)**

Once the vehicle is in riding mode, after five seconds the single maximum speed will return to real-time speed (Km/H) as shown below.



To return to display 1, press  button.

**Display of Powered Motor:** When motor is powered, the LCD will display and animate the following interface to indicate the motor is drawing power. This will only last a duration of 5 seconds before reverting to display 1. The interface will appear as follows.

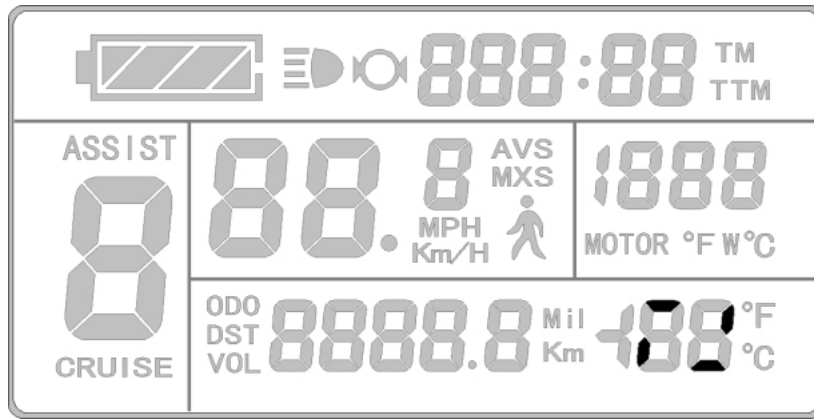

**Display of Powered Motor**

**Display of Power-Assist:** When motor is operating under power-assistance, the display interface flashes the “ASSIST” sign. The indicator will cease after 5 seconds.

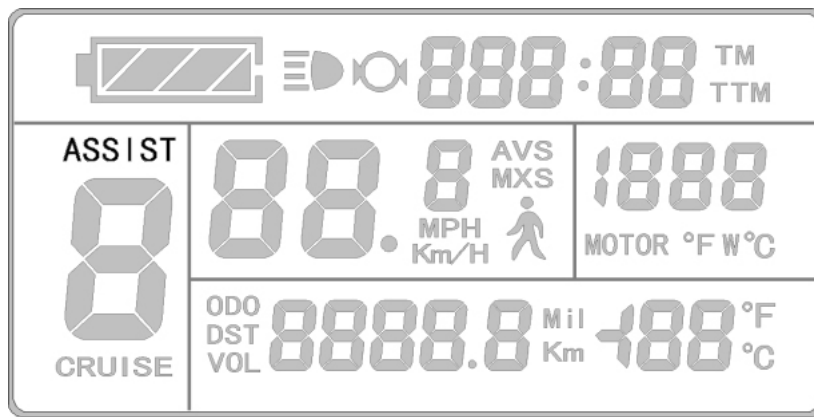



**Display of Power-Assist**

## Battery Capacity Indicator



The KT-LCD3 can identify 24V, 36V, 48V battery capacities when used with supporting controllers. When the battery capacity is over 70%, four bars from the battery indicator will be displayed. As the battery capacities drop, the bars will change accordingly. Once the power capacity is less than 15%, the battery indicator will be empty and show zero bars. If the power display frame flashes, it is due to voltage shortage where the controller will power off.



## PAS Ratio

Press  button or  button to adjust the power assist ratio, changing the motor output power. Range of power assist is between 1 and 5 (this can also be configured according to the rider’s requirements), where one provides the lowest power and five provides the highest. When the PAS ratio is set to zero, the power assist function is off.

## Power Push Function

Users can use power push function for assistance in vehicle take-off. Hold  button and the motor will provide power until vehicle reaches 6 Km/H. The meter assist function icon  will flash indicating the function is active. By releasing the  button, the function will be revoked.

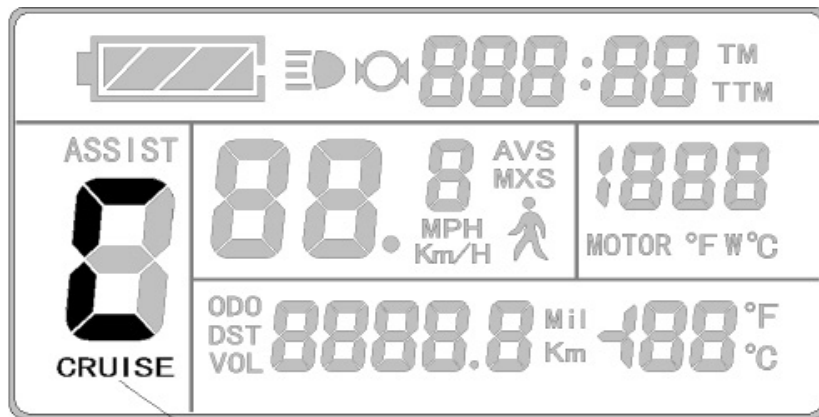

## Cruise Function

When the vehicle is traveling above 7Km/H, hold  button for 3 seconds to set the cruise function. The LCD will display "CRUISE" and "C" to indicate that the cruise function has been activated (as seen in the figure below). Brake or hold any button to revoke cruise. Note that this feature only works if it has been activated through the parameter settings (check C7 in parameter setting).



**Cruise Function**

## Backlight and Headlights

To turn on or off LCD backlight and vehicle headlights, hold  button for 3 seconds. When this function is activated, the display will show  sign to indicate it is on.

**Startup Backlights  
and Headlights**

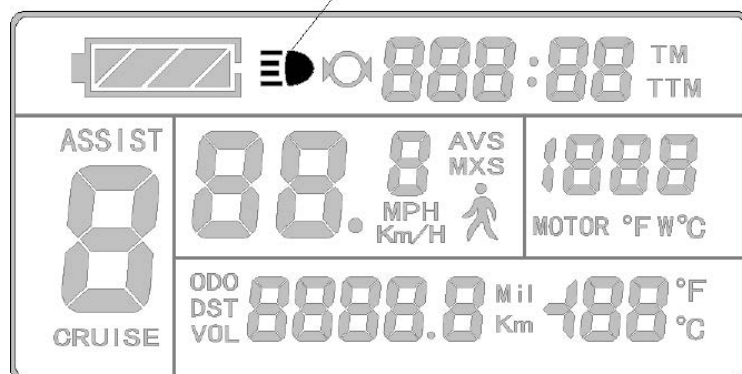

## Motor Operating Power and Temperature

Whilst vehicle is in use, real time feedback of input power to the motor is displayed on the meter. The operating temperature of the motor can be displayed with supporting sensors installed in the inner motor to output the temperature for signal detection. When the motor operating temperature exceeds the warning value, temperature display flashes to alarm the rider. In this circumstance, the motor controller will offer the appropriate protection to motor.

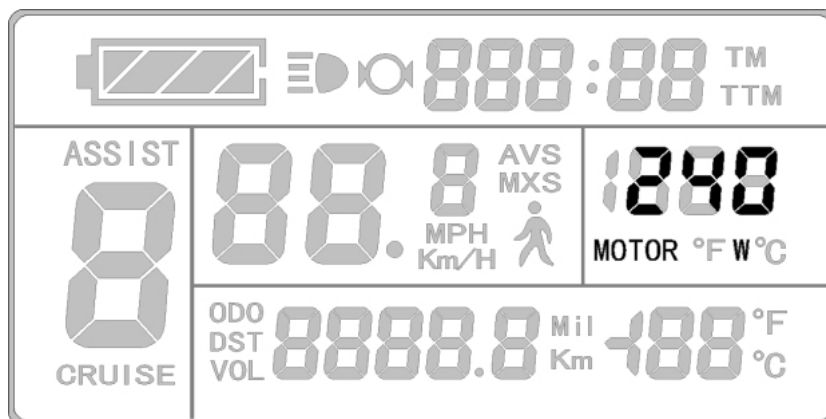

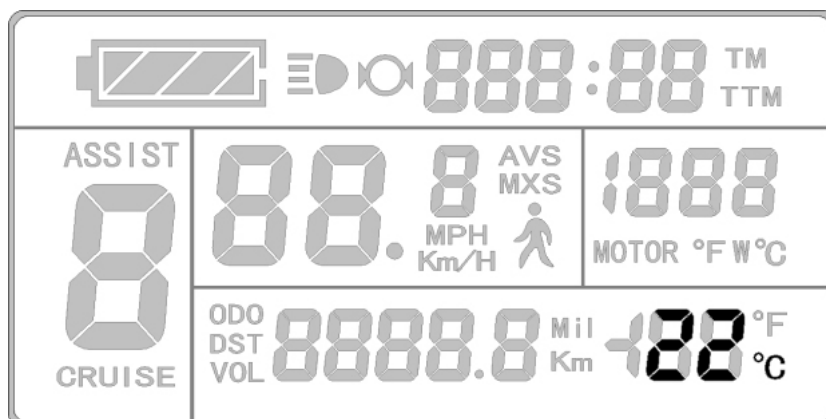

## Ambient Temperature

Upon start-up, the environment temperature is displayed on the bottom right hand corner. The displayed figure may not accurately indicate the environment temperature immediately after start up, however will adjust within 10 minutes.



## Single Data Clearing

After five seconds of start up, whilst on display 1 hold both the  button and the button  simultaneously for 3 seconds. The single trip time (TM) and single trip distance (DST) will flicker. Press  button and the record contents of both will be cleared. If there are no operations within five seconds of (TM) and (DST) flashing, the meter will return to display 1, and the original record content will be saved.





## Automatically Prompt Interface

**Error Code Display:** When there are issues with the electronic control system of the vehicle, the meter will automatically display (flicker) a fault code. This cannot be removed until fault is fixed. Refer to Error Code & Definition Table for reference.

**Motor operating temperature alarm:** When the motor operating temperature exceeds the warning value, the motor operating temperature display flashes to alarm the rider, whilst the controller will provide the appropriate protection to the motor.

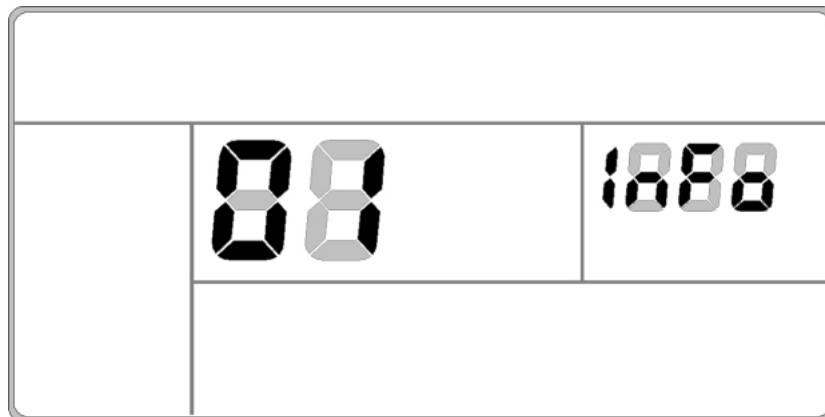

**Error Code Display**



Error Code & Definition Table:







Error Code	Definition
01_info	Throttle Abnormality
03_info	Motor Hall Signal Abnormality
04_info	Torque Sensor Signal Abnormality
05_info	Axis Speed Sensor Abnormality
06_info	Motor or Controller Short Circuited

# USER SETTING PROJECT

The KT-LCD3 meter provides users with 3 depths of settings which are s:





- General Project Setting
- P Parameter Setting
- C Parameter Setting

To enter the general project setting, simultaneously hold  button and  button for 3 seconds within 5 seconds of turning the meter on. The current setting will be indicated by a flashing sign. To scroll through the menu, press the  button.

Once the general project menu has been cycled through, the display will cease flashing. Now enter the P Parameter settings by simultaneously holding  button and  button for 3 seconds. The same method to scroll through the menu can be applied and the meter will flash specific icons indicating the setting currently open. Once the flashing has stopped, hold down both the  and  button again to progress to the C parameter settings. To exit these settings at any stage, simply hold down the  button where the meter will return to display 1. If no button operation occurs for 60 seconds whilst in a settings menu, the KT-LCD3 will discard changes and return to display 1. To exit at any moment, hold  and the meter will discard any unsaved changes and revert to display 1.

## GENERAL PROJECT SETTING



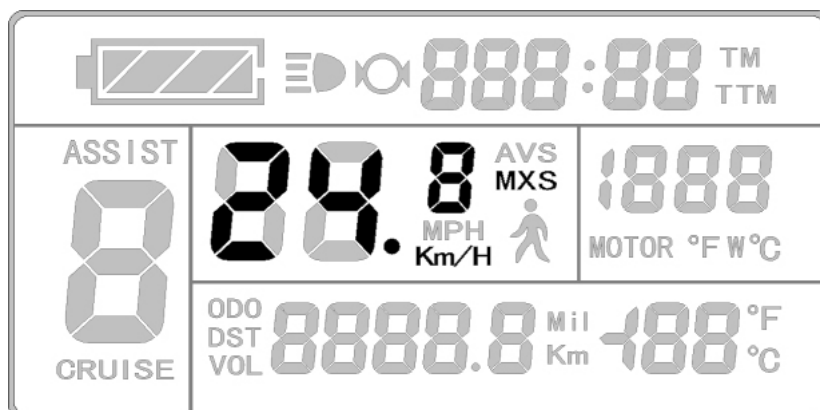

### Maximum Trip Speed

Turn on meter, and within 5 seconds of start-up simultaneously hold  button and  button for 3 seconds to enter general project settings. "MXS" and the speed will be displayed, indicating the maximum riding speed (Refer to image below for illustration). To adjust, press the  button to increase or  button to decrease the speed. Once desired speed has been selected, press the  button to confirm changes and move onto wheel diameter.







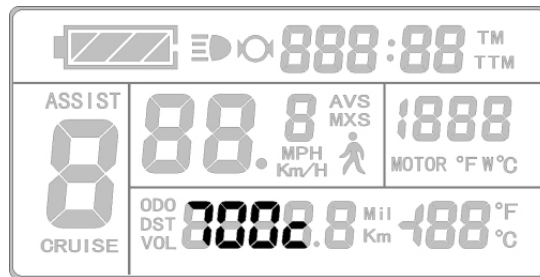

## Wheel Diameter

While in the general project setting, cycle through the menu using the  button until the values of "DST" are flashing. Use the  button and  button to scroll through the selection of the following wheel diameters: 6, 8, 10, 12, 14, 16, 18, 20, 22, 24, 26, 700C and 28 inches. Confirm selection by pressing the  button.



## Units



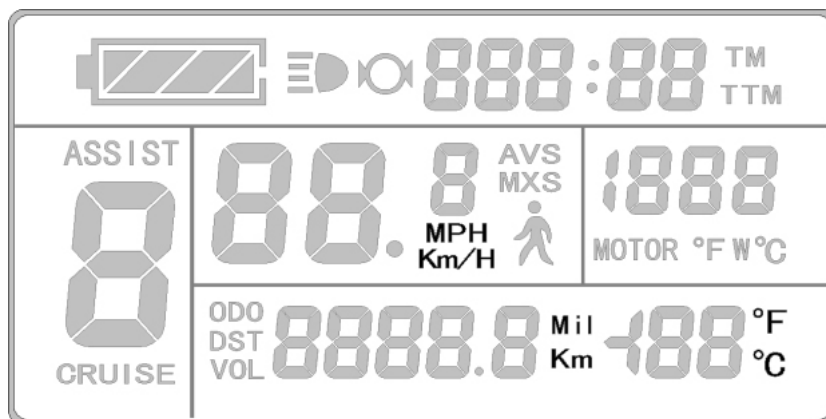



While in the general project setting, cycle through the menu using the  button until the values of units are flashing (as shown below). Use the  button and  button to scroll through the selection of units. Confirm selection by pressing the  button.



Definition Table of Metric/Imperial Units:

Unit	Metric	Imperial
Speed	Km/H	MPH
Distance	Km	Mil
Temperature	°C	°F

# P PARAMETER SETTING

Enter the P Parameter settings by cycling through the General Project Settings to the end (when display ceases flashing) and simultaneously holding  button and  button for 3 seconds. If required to exit at any parameter, hold  button for 2 seconds. Use the  button and  button to select the value and confirm selection by pressing the  button. The parameter will be saved and the meter will enter the next P parameter settings.

## P1 Motor Characteristic Parameter Setting

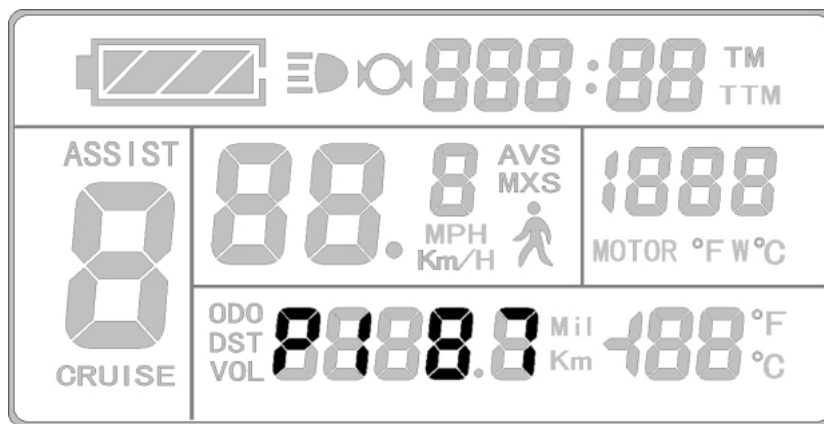

**P1 Display**

The P1 settings are a motor characteristic parameter where:

$$P1 = \text{Motor Gear Reduction Ratio} \times \text{Number of Rotor Magnets}$$

Rounding to a full number is necessary. The P1 setting ranges between 1 and 255.

## P2 Wheel Speed Pulse Signal Setting

The P2 parameter setting will display on the meter after the P1 parameter setting has been selected and confirmed. The KT-LCD3 will display as follows:

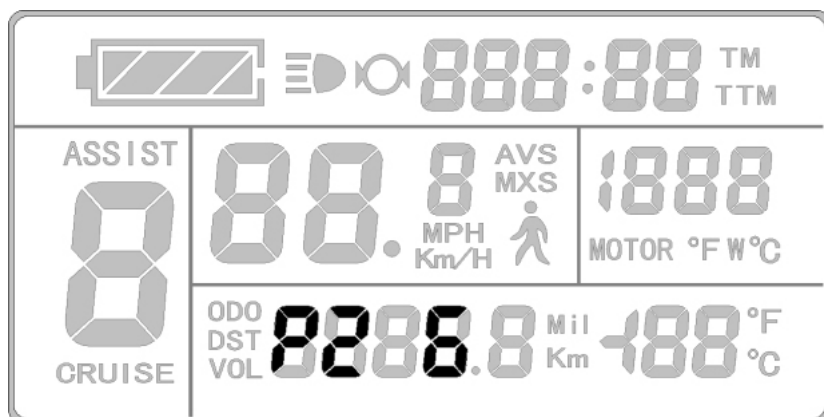

**P2 Display**

The P2 parameter is a setting mode for wheel speed pulse signal. If wheel generated 1 pulse signal by a revolution, the P2 value should be set to 1. If the wheel generated 6 pulse signals by a revolution, P2 should be set as 6. If users did not configure the parameter then P2 can be set to 0. The selection of P2 values ranges from 0 to 6.

## P3 Power Assist Control Setting

The P3 parameter setting will display on the meter after the P2 parameter setting has been selected and confirmed. The KT-LCD3 will display as follows:

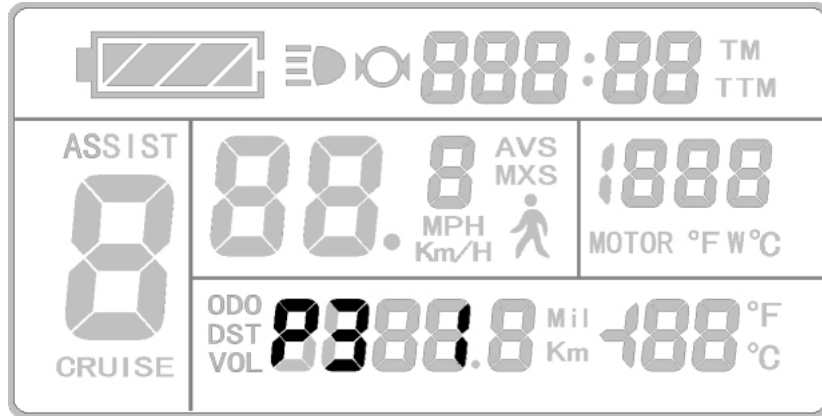

**P3 Display**

P3 parameters affect the power assist control setting. When the value is set to 0, the throttle is dependent on the PAS Gear Ratio. This means when the PAS gear ratio is 1, the throttle will provide the least amount of power, whereas when it is 5, the throttle will provide the most power. If the P3 parameter is set to 1, the throttle will provide the maximum power regardless on the PAS gear ratio chosen.

## P4 Throttle Start-Up Setting

The P4 parameter setting will display on the meter after the P3 parameter setting has been selected and confirmed. The KT-LCD3 will display as follows:



**P4 Display**

The P4 settings is for controlling the throttle activation. When the P4 parameter is 1, the throttle is under "non-zero startup" where the throttle will only activate the motor after the motor has been activated via pedaling. Setting the P4 to 0 will set the throttle to activate the motor when triggered.

## P5 Power Monitoring Setting



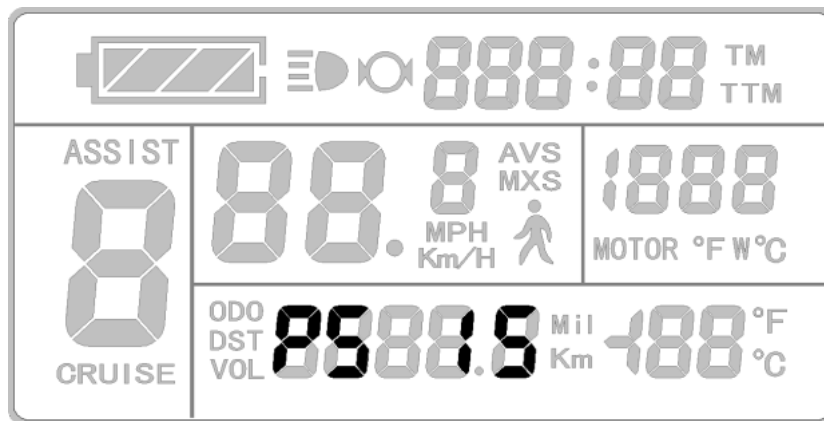



The P5 parameter setting will display on the meter after the P4 parameter setting has been selected and confirmed. The KT-LCD3 will display as follows:



**P5 Display**

The P5 Parameter is power monitoring mode. When the value is set to 0, the power monitoring is in "real-time voltage" mode where the method to determine the battery capacity is based on real-time voltage. Once the P5 parameter is set to a specified value, the power monitoring is in "smart power" mode where the value set is determined by the battery characteristics. Such that, 24V lithium batteries are typically set between 4-11 and 36V lithium batteries set between 5-15. The P5 parameter setting ranges from 0-40.

## C PARAMETER SETTING

Enter the C Parameter settings by cycling through the P Parameter Settings to the end (when display ceases flashing) and simultaneously holding  button and  button for 3 seconds. If required to exit at any parameter, hold  button for 2 seconds. Use the  button and  button to select the value and confirm selection by pressing the  button. The parameter will be confirmed and the meter will enter the following C parameter settings.

# C1 Throttle Start-Up Setting

The C1 parameter setting will display on the meter after the P Parameter settings. The KT-LCD3 will display as follows:

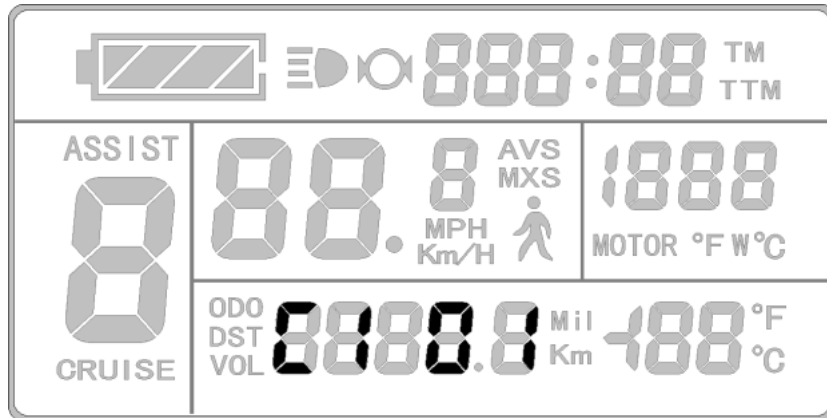

**C1 Display**

C1 settings are the power assist sensor parameters. Its definition is shown in the following table. As it can be seen from the table, the values for this parameter range from 0 to 7.

KUNTENG Power Assist Sensors	C1 Value	Start Sensitivity	KUNTENG V12 Power Assist Sensors	C1 Value	Start Sensitivity
Forward 5 Signal	00	Standard	Reverse 6 Signal	05	Standard
	01	Lower		06	Lower
	02	Lowest		07	Lowest
Forward 8 Signal	00	Higher	Reverse 10 Signal	05	Higher
	01	Standard		06	Standard
	02	Lower		07	Lower
Forward 10 Signal	00	Highest	Reverse 12 Signal	05	Highest
	01	Higher		06	Higher
	02	Standard		07	Standard



**Forward power sensor signal waveforms**



**Reverse power sensor signal waveforms**

## Forward and Reverse Waveform

## C2 Motor Phase Classification Coding Mode

The C2 parameter setting will display on the meter after C1 settings. The KT-LCD3 will display as follows:

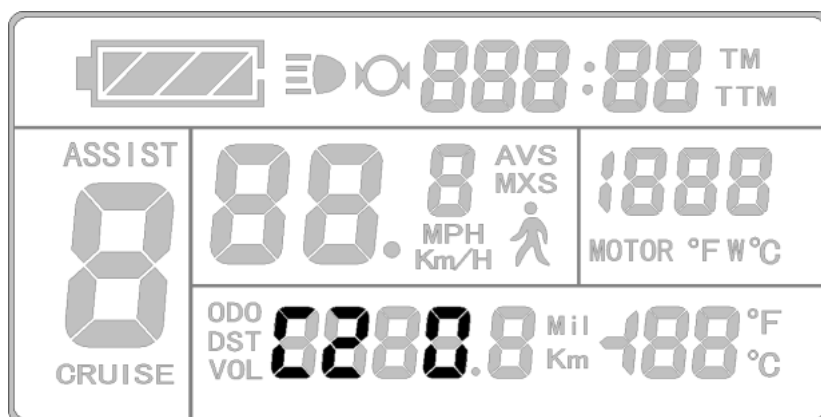

**C2 Display**

C2 parameters set the different phases of the motor when using a sine wave drive. The default value is 0, indicating that the used Quantum motor phase is standard. When the parameter is set as a specified value, a particular motor phase is selected. The range of values for C2 are between 0-7.

## C3 Power Assist Ratio Gear Initialization

The C3 parameter setting will display on the meter after C2 settings. The KT-LCD3 will display as follows:

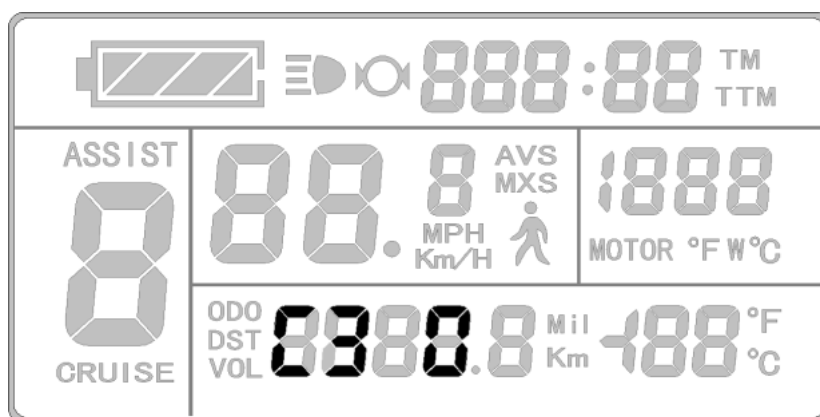

**C3 Display**

C3 parameters are settings for the power assist ratio gear upon start-up, where if the rider desires the bike to start up with a power assist ratio gear of 3, the C3 setting should be set to 3. The setting range for the C3 parameters are 0-8 (0-5 are only used. Production errors produced additional settings of 6-8.

## C4 Handlebar Function Setting

The C4 parameter setting will display on the meter after C3 settings. The KT-LCD3 will display as follows:

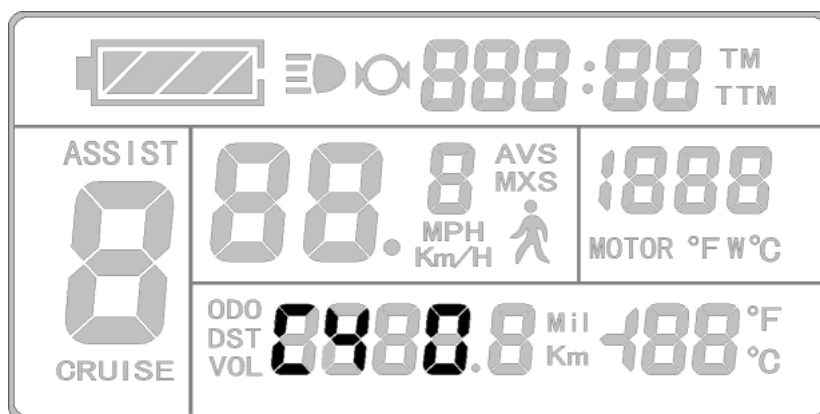

**C4 Display**

C4 settings are for the handlebar functions. The setting range is 0-4. This is accompanied by a table below, defining each value.

C4 Value	Throttle startup Mode P4 = 0	Throttle Startup Mode P4 = 1
0	Zero startup handlebar	Non-zero startup
1	Zero startup, throttle speed limited to 6km/h	Throttle limited to 6km/h before pedaling and provides full speed after pedal assist
2	Zero startup, throttle speed limited to rider's specification	Non-zero startup, throttle speed limited to rider's specification
3	Zero startup, zero gear effectively	Retain
4	Throttle gears is distinguished according to the display meter	Throttle gears is distinguished according to the display meter
5	Retain	Retain

## C5 Handlebar Function Setting

The C5 parameter setting will display on the meter after C4 settings. The KT-LCD3 will display as follows:

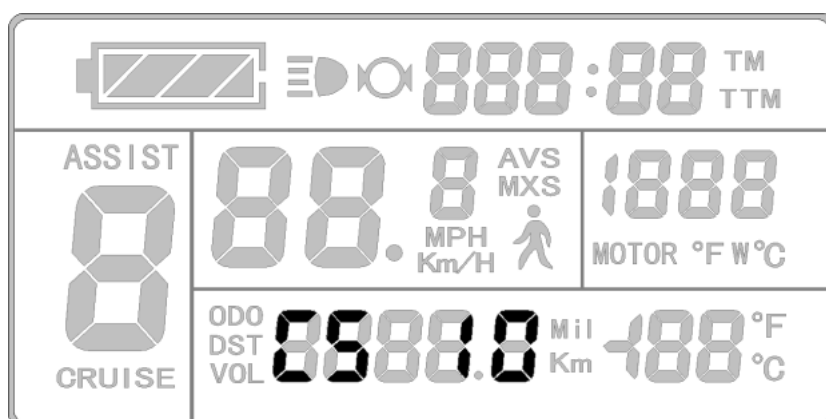

**C5 Display**

C5 settings are for controlling the maximum operating current. The default value is 10 and value ranges from 0 to 10. Refer to table below for definition of each value.

C5 Value	Maximum Current Value (A)
00	Undefined
01	Undefined
02	Undefined
03	Maximum Current Value ÷ 2.00
04	Maximum Current Value ÷ 1.50
05	Maximum Current Value ÷ 1.33
06	Maximum Current Value ÷ 1.25
07	Maximum Current Value ÷ 1.20
08	Maximum Current Value ÷ 1.15
09	Maximum Current Value ÷ 1.10
10	Maximum Current Value

## C6 Handlebar Function Setting

The C6 parameter setting will display on the meter after C5 settings. The KT-LCD3 will display as follows:

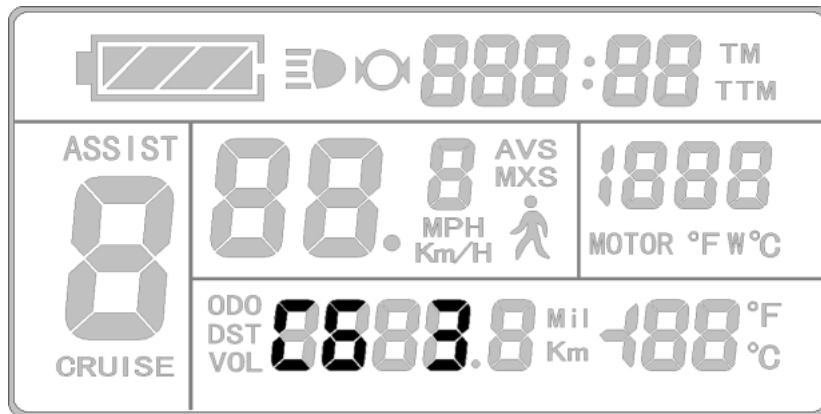

**C6 Display**

C6 settings are for the meter's backlight brightness. The default value is 3 and the setting range is 1-5.

C6 Value	Backlight Brightness
1	Dimmest
2	Darker
3	Standard
4	Brighter
5	Brightest



## C7 Cruise Function Setting

The C7 parameter setting will display on the meter after C6 settings. The KT-LCD3 will display as follows:

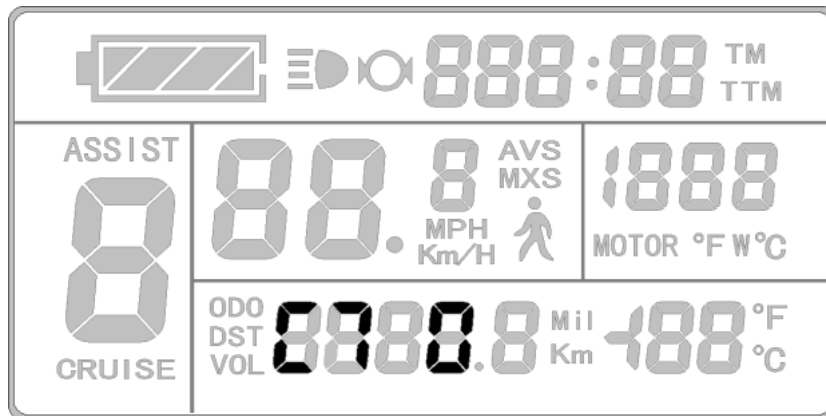

**C7 Display**

The cruise function settings can be found in C7. Refer to the following table for definitions of C7 values.

C7 Value	Cruise Function
0	Disabled
1	Enabled

## C8 Motor Operating Temperature Display Setting

The C8 parameter setting will display on the meter after C7 settings. The KT-LCD3 will display as follows:

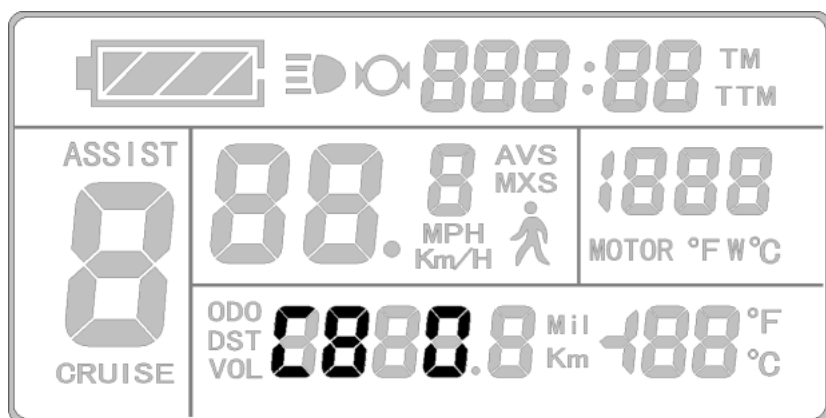

**C8 Display**

C8 is settings for the motor operating temperature display. Refer to the following table for definitions of the C8 values.

C8 Value	Motor Operating Temperature Function
0	Disabled
1	Enabled

## C9 Startup Password Setting

The C9 parameter setting will display on the meter after C8 settings. The KT-LCD3 will display as follows:

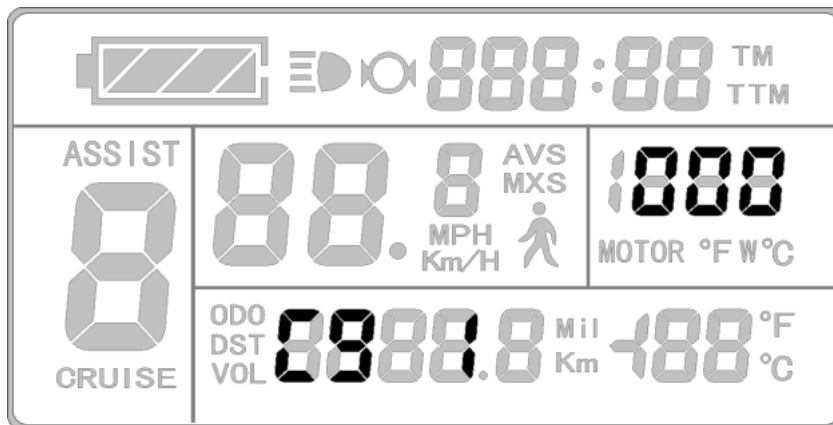

**C9 Display**



C9 is the settings for password feature upon startup. The default value is 0. Refer to the following table for definition of the function.

C9 Value	Password Function
0	Disabled
1	Enabled

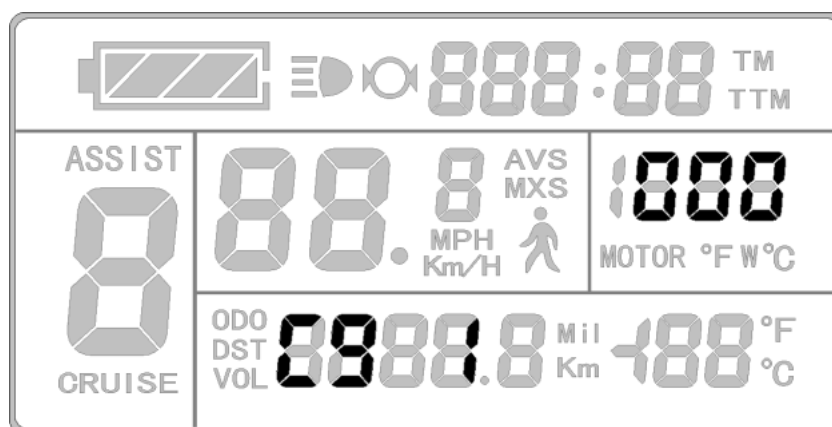
When the feature has been enabled and confirmed by pressing the  button, the display will change to the following.



**Password Setting Interface**

From here the rider can set the 3 digit passcode starting from the left and sequentially progress to the right. Password value range is 000-999. Select the values with the  button,  button, and confirming the selection with the  button.

**PLEASE NOTE:** If password is forgotten, the parameters can only be copied (see parameter copy) by data source meter prior to being decoded.

## C10 Restore Default Setting

The C10 parameter setting will display on the meter after C9 settings. The KT-LCD3 will display as follows:

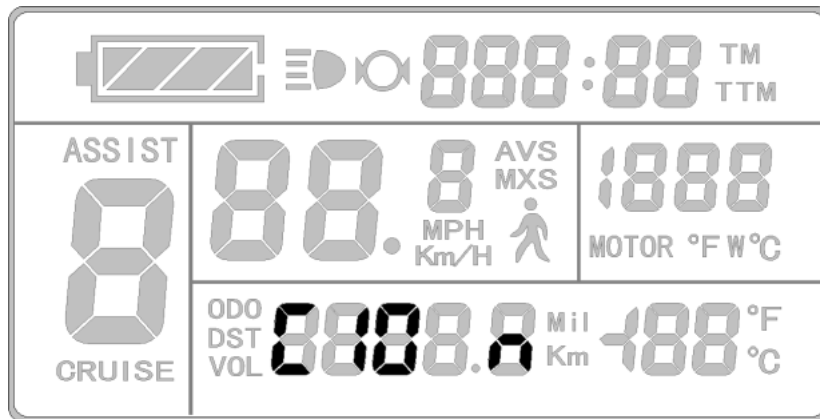

**C10 Display**

C10 restores the KT-LCD3 meter to default settings. Refer to table below for definitions.

C10 Value	Restore Default Setting
n	Disabled
y	Enabled

To restore the meter to default settings, select the C10 value "y" to enable the function and hold the  button for 2 seconds. All parameters will restore to default values and the meter will return to display 1.

## C11 Meter Attribute Setting

The C11 parameter setting will display on the meter after C10 settings. The KT-LCD3 will display as follows:

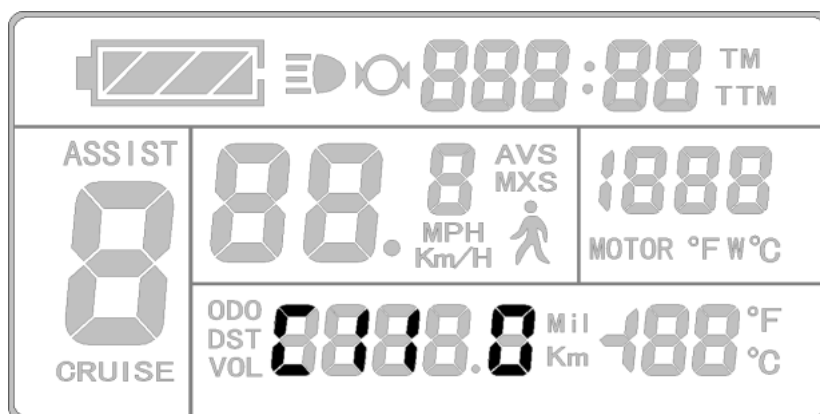

**C11 Display**

C11 is meter attribute settings. The setting range is 0-2. Refer to following table for definition of values.

C8 Value	Meter Attribute
0	Meter uses LCD3 new version of communication protocol, compatible with LCD1 and LCD3
1	Meter uses LCD1 and LCD2 old version communication protocol, it is not compatible with LCD3
2	As data source for copying parameters, the meter transfers the new LCD3 parameter to other meters

## C12 Controller Minimal Voltage Setting

The C12 parameter setting will display on the meter after C11 settings. The KT-LCD3 will display as follows:

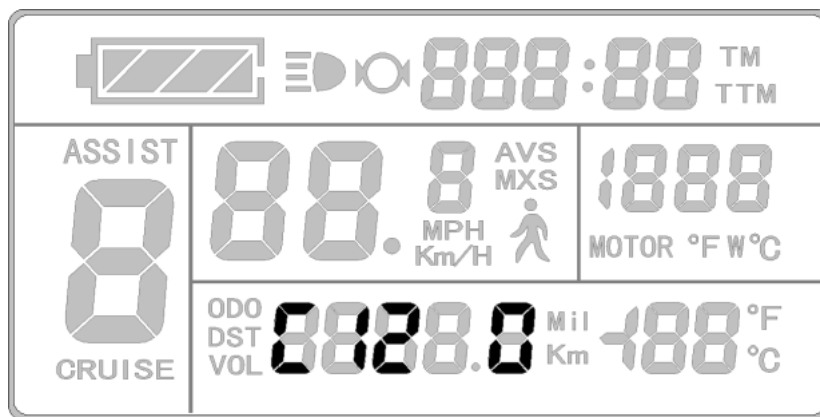

**C12 Display**

C12 parameters are settings for the controller's minimum operating voltage (voltage shortage value). Refer to the following table to calculate the minimum voltage.

C12 Value	Minimum Voltage (V)		
	24V Controller	36V Controller	48V Controller
0	Default Value-2V	Default Value-2V	Default Value-2V
1	Default Value-1.5V	Default Value-1.5V	Default Value-1.5V
2	Default Value-1V	Default Value-1V	Default Value-1V
3	Default Value-0.5V	Default Value-0.5V	Default Value-0.5V
4	Default Value=20V	Default Value=30V	Default Value=40V
5	Default Value+0.5V	Default Value+0.5V	Default Value+0.5V
6	Default Value+1V	Default Value+1V	Default Value+1V
7	Default Value+1.5V	Default Value+1.5V	Default Value+1.5V

## C13 ABS Brakes and Anti-Charge Control Setting

The C13 parameter setting will display on the meter after C12 settings. The KT-LCD3 will display as follows:

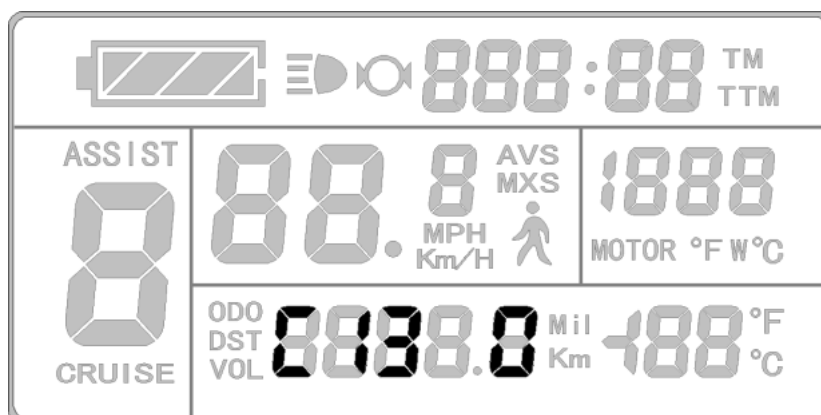

**C13 Display**

C13 parameters are settings for the ABS braking strength and anti-charge control. Refer to the following table for definitions of each C13 value.

C13 Value	ABS Braking Strength	Energy Recovery Efficiency
0	None	None
1	Class 1 Braking Strength	Best energy recovery
2	Class 2 Braking Strength	General energy recovery
3	Class 3 Braking Strength	Weaker energy recovery
4	Class 4 Braking Strength	Poor energy recovery
5	Class 5 Braking Strength	Bad energy recovery

The recommended value for the C13 parameter is 1. Other options should be selected with caution for use. Seek professional advice for assistance.

**Be sure to note:** the higher the braking intensity level, the higher the braking strength will be which results in greater damage to the motor shaft.

# C14 Power Assist Tuning Setting

The C14 parameter setting will display on the meter after C13 settings. The KT-LCD3 will display as follows:

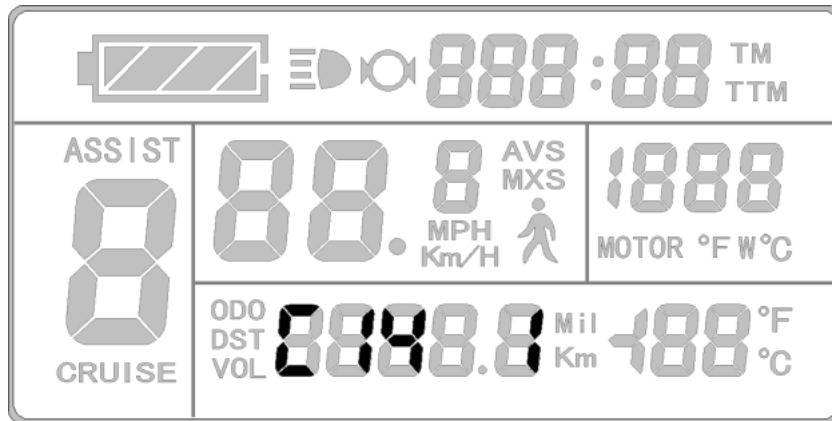

**C14 Display**

C14 is the parameters for power assist tuning. The default value is 2. Refer to the following table for definition of each value.

C14 Value	Assist Strength of Pedal Assist
1	Weaker
2	General
3	Stronger

## PARAMETER COPY

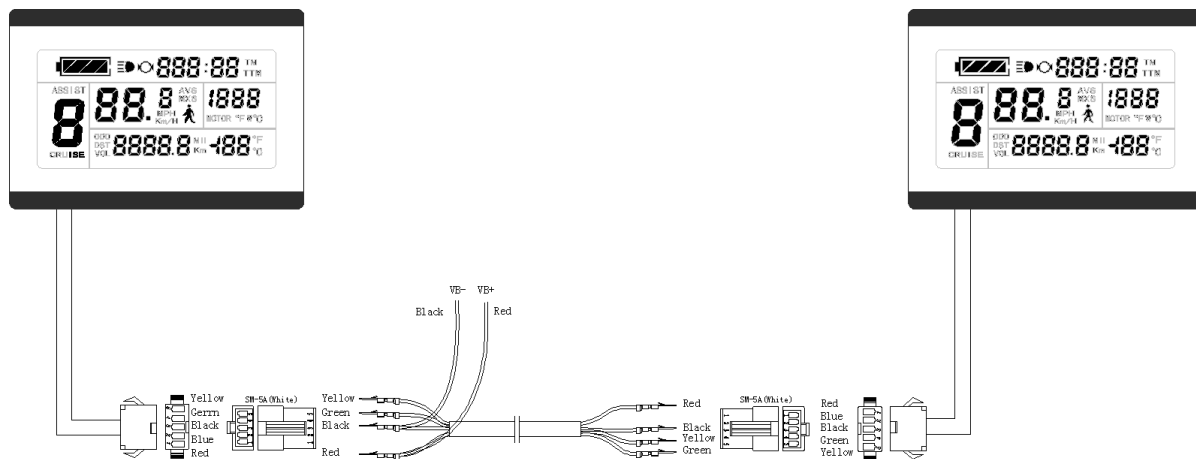

Set parameters (including general project parameters, P parameters and C parameters) of any KT-LCD3 meter can be copied to another KT-LCD3 meter. This can be done via C11 Meter Attribute Setting, where the meter can become a data source. Use special wiring cables to configure the meter as shown below.

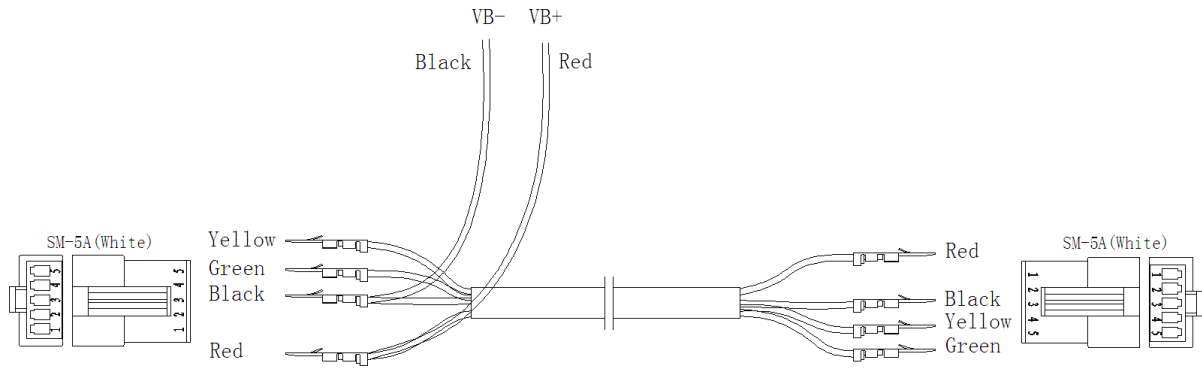

**Meter Parameter Copy Wiring Diagram**



### Special Wiring Cable

Correctly configure and wire the meters and provide a power supply of 48V, 36V or 24V (VB + positive power supply). Hold  button of the source meter until start up. Within 5 seconds, simultaneously hold  button and  button for 2 seconds. If successfully completed, the meter will copy the parameters and display the following interface.

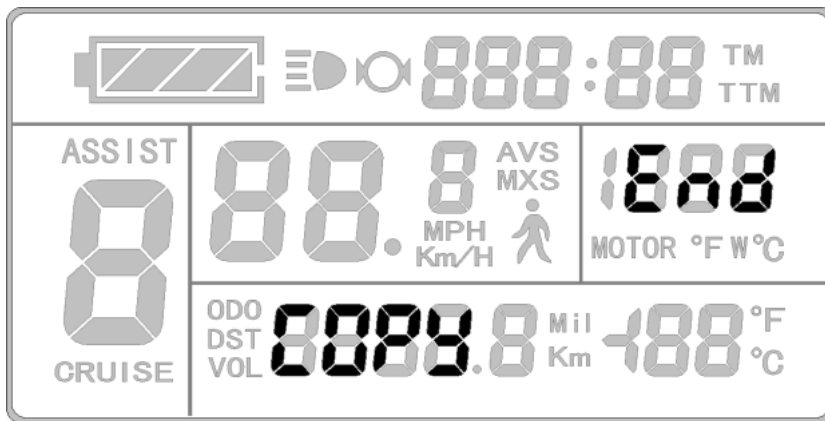

### Successful Copy Display

**Please Note:** Both C9 start up password and C11 meter attributes cannot be copied. And LCD3 meter can only copy to meter of same model.

## VERSION INFORMATION

KT\_LCD3\_V2.0

Released on October 20, 2014